

SPECIAL BRAKES



Testato e sviluppato direttamente nelle competizioni su pista del Trofeo Scooter 70 Evolution della Polini Italian Cup, il nuovo disco Polini assicura maggiore prontezza in frenata rendendo lo scooter decisamente più maneggevole grazie al minor peso del disco. La frenata è migliore in ogni condizione di guida e nelle staccate estreme a vantaggio della sicurezza. Lo smaltimento del calore in frenata è rapidissimo grazie al particolare disegno del perimetro esterno e dei fori di alleggerimento.

Tested and developed during the 70 Evolution Scooter races of the Polini Italian Cup, the new Polini disc grants more quickness during the braking. Furthermore the scooter is easier to handle thanks to the lighter disc. The braking is better at every driving condition and during the shifting down, improving the safety level. The warm disposal during the braking is very fast thanks to the design of the external perimeter and of the lightening holes.



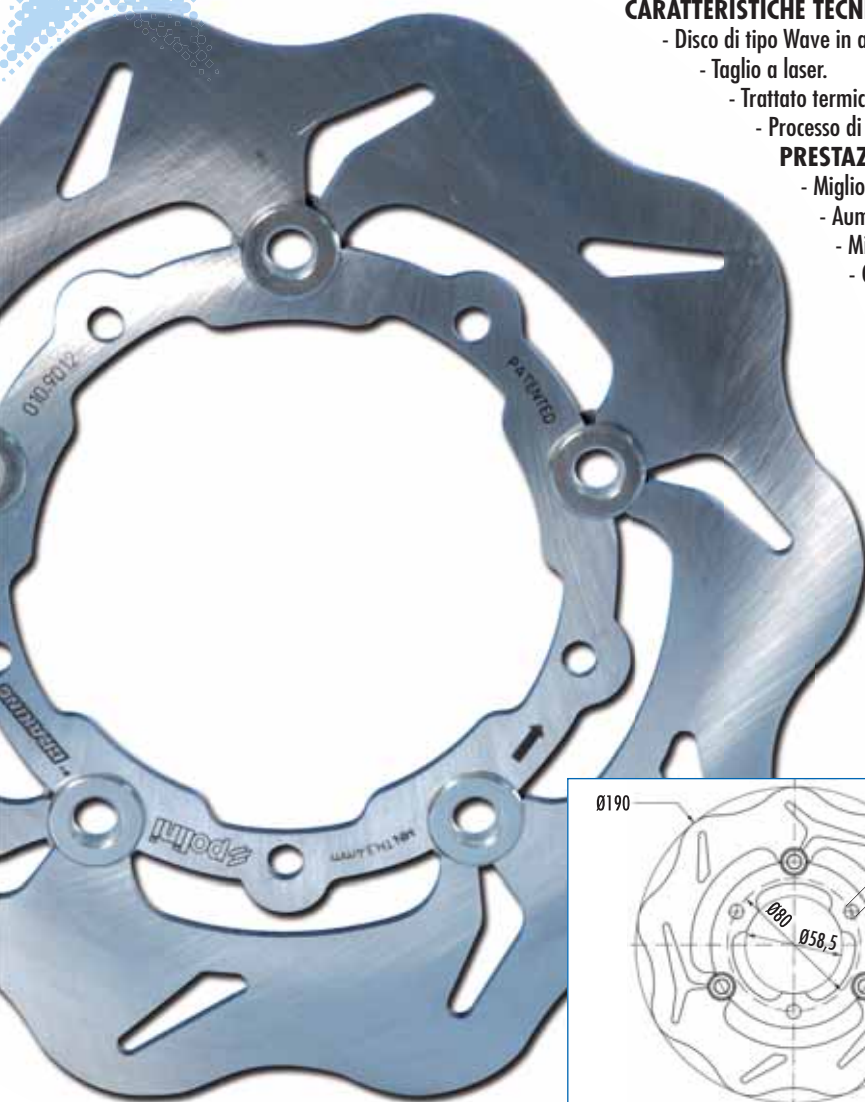

CARATTERISTICHE TECNICHE

- Disco di tipo Wave in acciaio AISI420.
- Taglio a laser.
- Trattato termicamente.
- Processo di lavorazione e finiture su impianti produttivi CNC.

PRESTAZIONI

- Migliore prontezza di risposta e modulabilità in frenata.
- Aumento della maneggevolezza del veicolo.
- Miglior raffreddamento.
- Controllo delle dilatazioni alle alte temperature che si traducono in una resistenza ottimale anche alle sollecitazioni più estreme.
- Ottimizzazione nell'utilizzo delle pastiglie.

TECHNICAL FEATURES

- Wave disc made of AISI420 steel
- Laser cutting
- Thermally treated
- Working process and finishing touches on CNC productive system

PERFORMANCE

- More quickness in the response of the vehicle and easy to modulate during the braking process
- Increase of the handiness of the vehicle
- Better cooling
- Control of the thermal expansion to the highest temperature giving an optimal resistance to the most extreme stresses.
- Optimization of the pads use

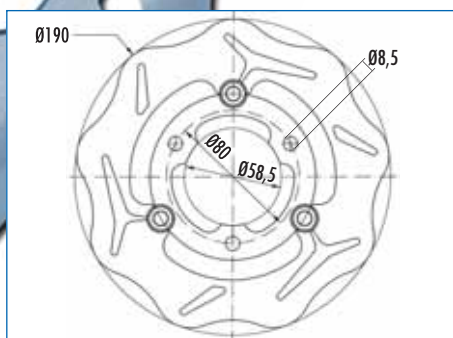

175.0001 spessore / thickness 4 mm.

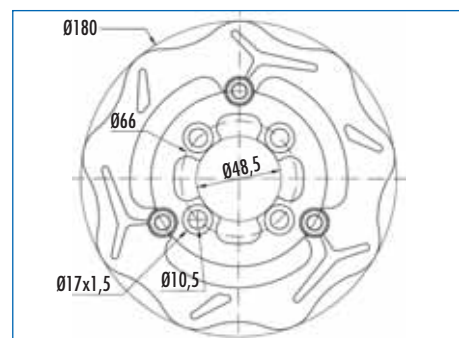

175.0002 spessore / thickness 4 mm.

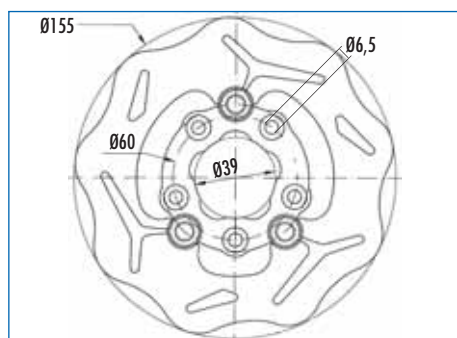

175.0003 spessore / thickness 4 mm.

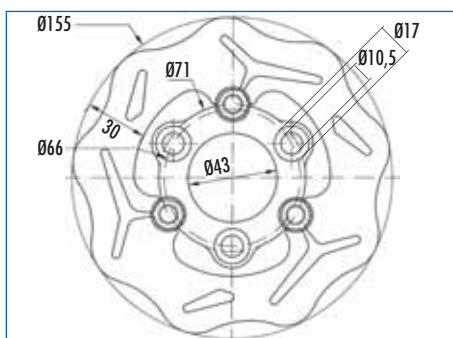

175.0004 spessore / thickness 4 mm.

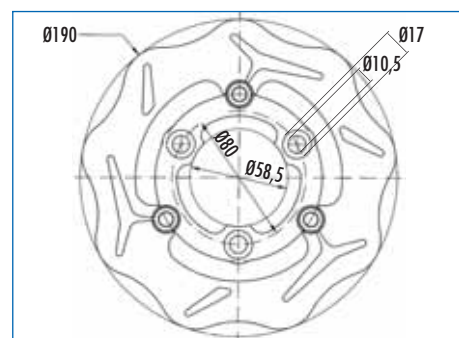

175.0005 spessore / thickness 4 mm.

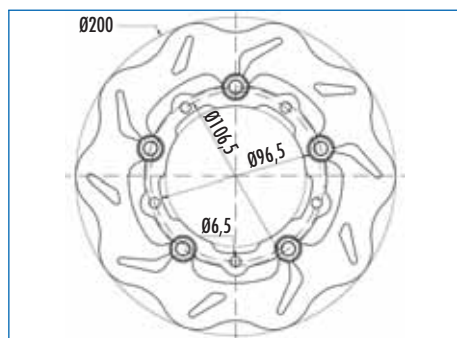

175.0006 spessore / thickness 4 mm.

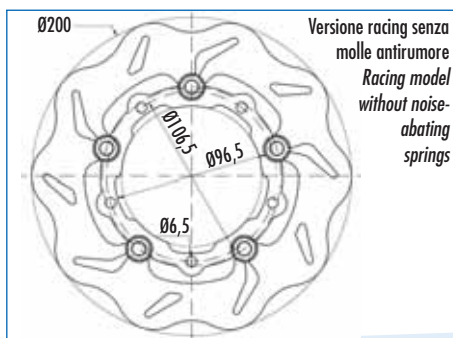

175.0007 spessore / thickness 4 mm.

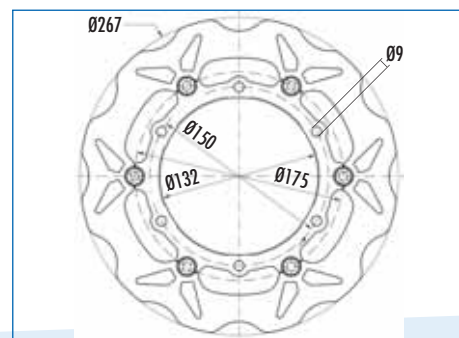

175.0008 spessore / thickness 5 mm.

APPLICAZIONI DISCHI FRENO - BRAKE DISC USE

MARCA BRAND	MODELLO MODEL	C.C.	ANNO YEAR	A=Anteriore Front P=Posteriore Rear	CODICE ITEM
APRILIA	AMICO SPORT LX (GC/G799)	50	1992	A	175.0004
"	AREA 51	50	1998-2002	P	175.0001
"	AREA 51 SBK	50	2000-2002	P	175.0001
"	GULLIVER (LH02/H126)	50	1997-1999	A	175.0001
"	HABANA (PK/K385)	50	1998-2002	A	175.0001
"	LEONARDO (MB/H689)	150	1997-1998	P	175.0001
"	LEONARDO (MB00/H287)	125	1996	P	175.0001
"	LEONARDO (MB00/H287)	125	1997-1998	P	175.0001
"	LEONARDO (MB00/H287)	125	1999 >	P	175.0001
"	LEONARDO ST (MB/H689)	150	1999 >	P	175.0001
"	RALLY	50	1995-2000	A	175.0001
"	RALLY LC (MD/H062)	50	1997 >	A	175.0001
"	RALLY LC (MD/H062)	50	1997 >	P	175.0001
"	SCARABEO DE-LUX	50	1998 >	P	175.0001
"	SCARABEO DITECH (SC,TG,TH/EBE)	50	2001 >	P	175.0001
"	SONIC (PB/K002)	50	1998 >	A	175.0004
"	SONIC GP (PB/K002)	50	1998 >	A	175.0004
"	SR	50	1994-2000	A	175.0001
"	SR (PX/K508)	150	1999-2003	A	175.0001
"	SR (PX125/K4740)	125	1999-2003	A	175.0001
"	SR 2004 CARBURATORE (PIAGGIO)	50		A	175.0001
"	SR DITECH (RL/e3/0012)	50	2001-2006	A	175.0001
"	SR DITECH (RL/e3/0012)	50	2001-2006	P	175.0001
"	SR R FACTORY	50	2005-2006	A	175.0001
"	SR STEALTH LC (LY/H639)	50	1996-2000	A	175.0001
"	SR STEALTH LC (LY/H639)	50	1996-2000	P	175.0001
"	SR STREET	50	2005 >	A	175.0001
"	SR STREET	50	2005 >	P	175.0001
BETA	ARK (BS/K529) (BS4/e1/00114)	50	1997 >	A	175.0001
"	ARK LC (BS/K529)	50	1999 >	A	175.0001
"	ARK LC (BS/K529)	50	1999 >	P	175.0001
"	CHRONO 13	50	1994-1999	A	175.0001
"	TEMPO 13	50	1995-1996	A	175.0001
GILERA	DNA 2T LC	50	2000 >	P	175.0006 *
"	EASY MOVING	50	1996 >	A	175.0004
"	NRG	50	1994 >	A	175.0001
"	STALKER DD (C13/H675)	50	1997-2001	A	175.0001
"	STALKER DT	50	1997-2005	A	175.0001
"	STORM	50	1994 >	A	175.0001
"	TYPHOON	50	1993 >	A	175.0001
"	TYPHOON X	50	1993 >	A	175.0001
HONDA	BALI SJ (AF32/H030)	50	1993-1997	A	175.0005
"	BALI SJ (HF07/H328)	100	1996 >	A	175.0005
"	CH SPACY	125	1998 >	A	175.0005
"	SKY DX (AF43/H893)	50	1997 >	A	175.0005
"	YUPI	50	1990 >	A	175.0005

MARCA BRAND	MODELLO MODEL	C.C.	ANNO YEAR	A=Anteriore Front P=Posteriore Rear	CODICE ITEM
MALAGUTI	F 12 - PHANTOM	50	1994-1997	A	175.0001
"	F 12 - PHANTOM	50	1998 >	A	175.0001
"	F 12 - PHANTOM LC	50	1995-1997	A	175.0001
"	F 12 - PHANTOM LC	50	1998 >	A	175.0001
"	F 12 DIGIT KAT- PHANTOM	50	2000 >	A	175.0001
"	F 12 DIGIT KAT- PHANTOM LC	50	2000 >	A	175.0001
"	F 12 R ARIA	50		A	175.0001
"	F 12 R LC	50		A	175.0001
"	F10	50	1992-1994	A	175.0003
"	F10	50	1995-2005	A	175.0003
"	F10 JET LINE	50	1997-1999	A	175.0003
"	YESTERDAY (45/H969)	50	1997-2001	A	175.0003
MBK	BOOSTER 12"	50	2000-2006	A	175.0002
"	BOOSTER NG (4VA/H268)	50	1997 >	A	175.0005
"	BOOSTER R - NG - ROCHET Euro 0-1	50	1993-1995	A	175.0004
"	BOOSTER SPIRIT Euro 2	50	1999 - 2005	A	175.0002
"	BOOSTER SPIRIT Euro 0-1	50	1996 - 1998	A	175.0004
"	EVOLIS	50	1992 - 1994	A	175.0004
"	EVOLIS	80	1994 >	A	175.0004
"	FIZZ	50	1994 >	A	175.0004
"	FORTE	50	1994 >	A	175.0004
"	NITRO (5BR/H949)	50	1997 - 2000	A	175.0005
"	NITRO (5BR/H949)	50	1997 - 2000	P	175.0005
"	NITRO (SA14/e13/0036)	50	2001 >	A	175.0005
"	NITRO (SA14/e13/0036)	50	2001 >	P	175.0005
"	NITRO (SB05/e13/0016)	100	1999 >	A	175.0005
"	OVETTO (5AD/H744)	50	1997 >	A	175.0001
"	OVETTO YN (SB04/e9/0016)	100	2000 >	A	175.0001
"	STUNT (SA09/e13/0017)	50	2000 >	A	175.0005
"	TARGET	50	1992 - 1994	A	175.0004
MOTRON	COMPACT WF	50	1988 - 1992	A	175.0003
PEUGEOT	ZENITH LUXE	50	1996 >	A	175.0003
PGO	BIG MAX	50	1994 - 2002	A	175.0004
"	BIG MAX	80	1995 >	A	175.0004
"	MEGA FIFTY	50	1999	A	175.0004
"	PMS	50	1999	A	175.0005
"	PMS	110	1999 >	A	175.0005
"	PMX (PM50/)	50	1997 >	A	175.0004
"	T REX	110	1999 >	A	175.0005
"	T REX (CP/e12/0007)	50	1999 >	A	175.0005
PIAGGIO	FLY (LEADER) Euro 2-3	125		A	175.0006 *
"	FLY (LEADER) Euro 2-3	150		A	175.0006 *
"	HEXAGON 2T LC LX	125	1998 >	A	175.0006 *
"	HEXAGON 2T LC LXT	180	1998 >	A	175.0006 *
"	HEXAGON 4T LX4	125		A	175.0006 *
"	NRG (SAL/H123)	50	1993 - 1995	A	175.0001

* Solo per uso agonistico in pista montare il cod.175.0007 (disco senza molle antirumore) - Fit item 175.0007 (disc without noise-abating spring) only for race use on track.

MARCA BRAND	MODELLO MODEL	C.C.	ANNO YEAR	A=Anteriore Front P=Posteriore Rear	CODICE ITEM
"	NRG (SAL/H123/0)	50	1996 - 2001	A	175.0001
"	NTT	50	1994	A	175.0001
"	NTT	50	1996 >	A	175.0001
"	SFERA 2T RESTYLING	50		A	175.0006 *
"	VESPA ET2 2T	50	1997 >	A	175.0006 *
"	VESPA ET2 2T CARBURATORE	50	1997 >	A	175.0006 *
"	VESPA ET4 (LEADER) 4T	125	1999 >	A	175.0006 *
"	VESPA ET4 (LEADER) 4T	150	1999 >	A	175.0006 *
"	VESPA ET4 4T	125	1996 >	A	175.0006 *
"	VESPA LX (LEADER) 4T	125		A	175.0006 *
"	VESPA LX (LEADER) 4T	150		A	175.0006 *
"	VESPA PX Euro 2	125	1998 > 2001	A	175.0006 *
"	VESPA PX Euro 2	150	1998 > 2001	A	175.0006 *
"	VESPA PX Euro 2	200	1998 > 2001	A	175.0006 *
"	VESPA S 2T Euro 2	50		A	175.0006 *
"	VESPA S 4V Euro 2 4T	50		A	175.0006 *
"	VESPA S Euro 3 4T	125		A	175.0006 *
"	VESPA S Euro 3 4T	150		A	175.0006 *
"	ZIP 4T	125	2000 >	A	175.0006 *
"	ZIP FAST RIDER 2T (SSL/G357)	50	1993 - 1995	A	175.0004
"	ZIP FAST RIDER 2T (SSL/G357)	50	1996 - 2000	A	175.0004
"	ZIP SP H20	50	2001 >	A	175.0006 *
VILLA	AX	50	1993 >	A	175.0004
"	GZ	50	1993 >	A	175.0004
YAMAHA	AEROX (SB05/e13/0016)	100	2000 - 2002	A	175.0005
"	AEROX (SB05/e13/0016)	100	2000 - 2002	P	175.0005
"	AEROX YQ (SBR/EBE) (SA14/e13/0036)	50	1997 >	A	175.0005
"	AEROX YQ (SBR/EBE) (SA14/e13/0036)	50	1997 >	P	175.0005
"	AXIS	50	1994 >	A	175.0004
"	BREEZE YM (4RC/G929)	50	1994 >	A	175.0004
"	BUMP (4VA/H268)	50	1997 - 2001	A	175.0002
"	BW'S	50	1993 - 1995	A	175.0004
"	BW'S	50	1996 - 1998	A	175.0004
"	BW'S	50	1999 - 2003	A	175.0002
"	BW'S	50	2000 - 2006	A	175.0002
"	BW'S NG (4BXM/G370) Euro 2	50	1996 >	A	175.0002
"	CR Z (4FW/-)	50	1992 - 1995	A	175.0004
"	JOG R/ RR (SA22/e9/0079)	50	2002 >	A	175.0005
"	JOG Z	50	1991 >	A	175.0004
"	NEO'S (SB04/e9/0016)	100	2000 >	A	175.0001
"	NEO'S YN (5AD/H744)	50	1997 >	A	175.0001
"	SLIDER (SA09/e13/0017)	50	1999 >	A	175.0001
"	SPY	50	1995 >	A	175.0002
"	T-MAX	500	2008 >	A	175.0008

* Solo per uso agonistico in pista montare il cod.175.0007 (disco senza molle antirumore) - Fit item 175.0007 (disc without noise-abating spring) only for race use on track.