

FRENI A DISCO FLOTTANTI - FLOATING BRAKE DISCS

CARATTERISTICHE TECNICHE

- Disco di tipo Wave in acciaio AISI420.
- Taglio a laser.
- Trattato termicamente.
- Processo di lavorazione e finiture su impianti produttivi CNC.

PRESTAZIONI

- Migliore prontezza di risposta e modulabilità in frenata.
- Aumento della maneggevolezza del veicolo.
- Miglior raffreddamento.
- Controllo delle dilatazioni alle alte temperature che si traducono in una resistenza ottimale anche alle sollecitazioni più estreme.
- Ottimizzazione nell'utilizzo delle pastiglie.

TECHNICAL FEATURES

- Wave disc made of AISI420 steel
- Laser cutting
- Thermally treated
- Working process and finishing touches on CNC productive system

PERFORMANCE

- More quickness in the response of the vehicle and easy to modulate during the braking process
- Increase of the handiness of the vehicle
- Better cooling
- Control of the thermal expansion to the highest temperature giving an optimal resistance to the most extreme stresses.
- Optimization of the pads use

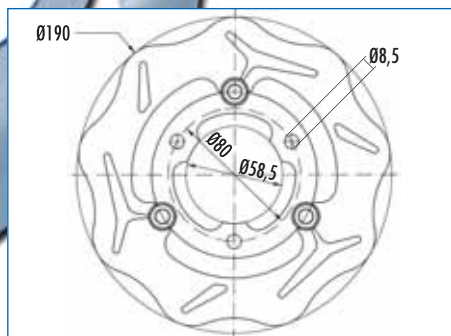

175.0001 spessore / thickness 4 mm.

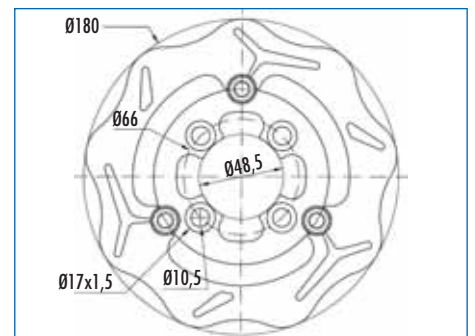

175.0002 spessore / thickness 4 mm.

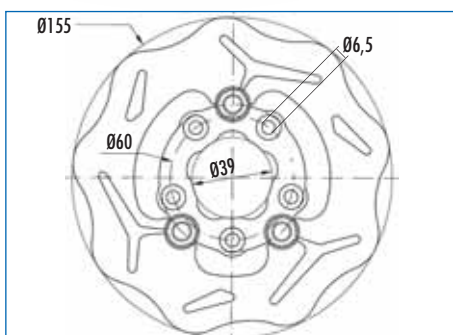

175.0003 spessore / thickness 4 mm.

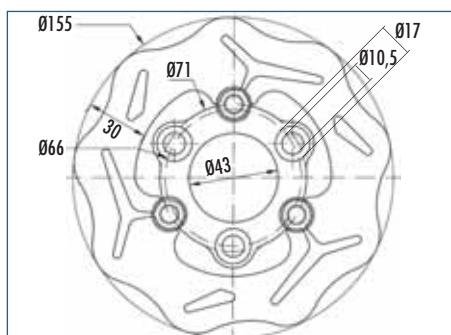

175.0004 spessore / thickness 4 mm.

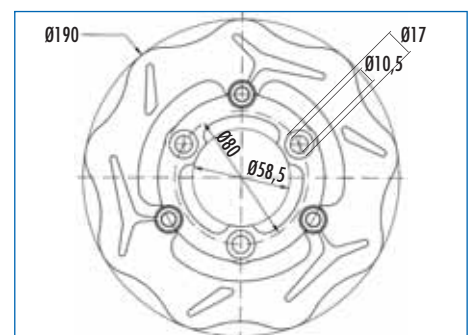

175.0005 spessore / thickness 4 mm.

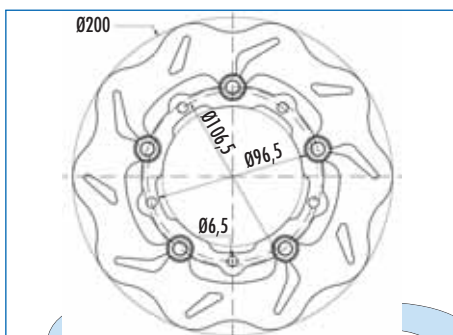

175.0006 spessore / thickness 4 mm.

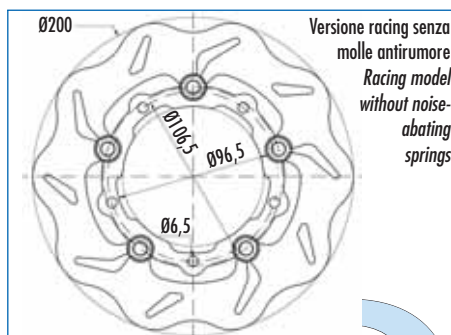

175.0007 spessore / thickness 4 mm.

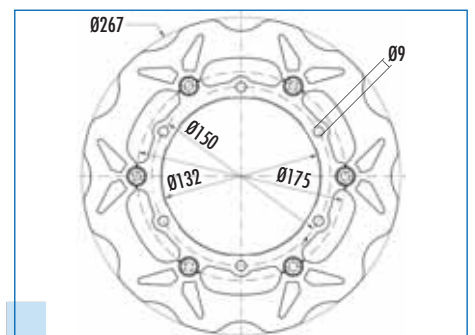

175.0008 spessore / thickness 5 mm.

FRENI A DISCO - BRAKE DISCS

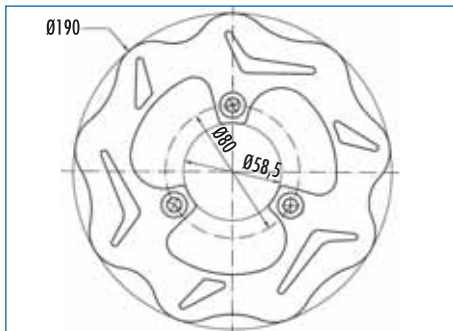

175.0011 spessore/thickness 4 mm.

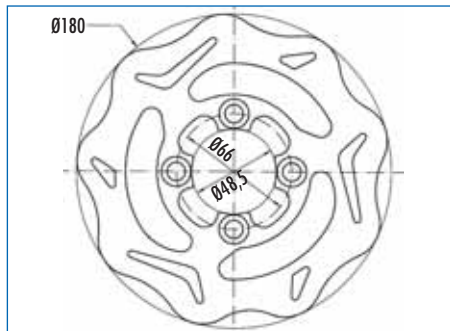

175.0012 spessore/thickness 4 mm.

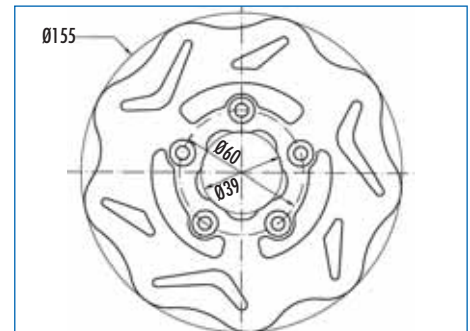

175.0013 spessore/thickness 4 mm.

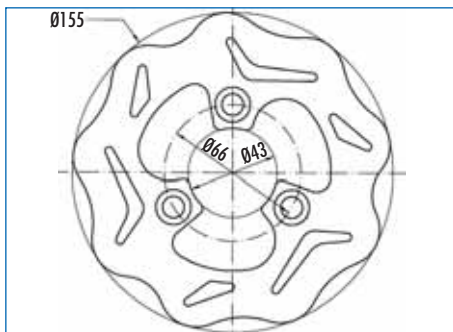

175.0014 spessore/thickness 4 mm.

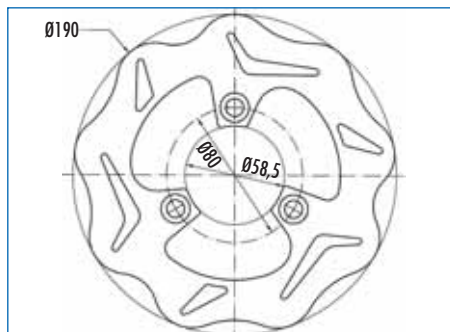

175.0015 spessore/thickness 4 mm.

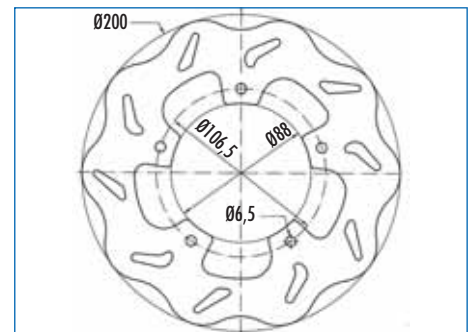

175.0016 spessore/thickness 4 mm.

APPLICAZIONI DISCHI FRENO - BRAKE DISCS USE

MARCA BRAND	MODELLO MODEL	CC	ANNO YEAR	A=Ant. Front P=Post. Rear	FLOATING DISC	FIXED DISC	MARCA BRAND	MODELLO MODEL	CC	ANNO YEAR	A=Ant. Front P=Post. Rear	FLOATING DISC	FIXED DISC
APRILIA	AMICO SPORT LX (GC/G799)	50	1992	A	175.0004	175.0014	"	SR DITECH (RL/e3/0012)	50	2001-2006	P	175.0001	175.0011
"	AREA 51	50	1998-2002	P	175.0001	175.0011	"	SR R FACTORY	50	2005-2006	A	175.0001	175.0011
"	AREA 51 SBK	50	2000-2002	P	175.0001	175.0011	"	SR STEALTH LC (LY/H639)	50	1996-2000	A	175.0001	175.0011
"	GULLIVER (LH02/H126)	50	1997-1999	A	175.0001	175.0011	"	SR STEALTH LC (LY/H639)	50	1996-2000	P	175.0001	175.0011
"	HABANA (PK/K385)	50	1998-2002	A	175.0001	175.0011	"	SR STREET	50	2005>	A	175.0001	175.0011
"	LEONARDO (MB/H689)	150	1997-1998	P	175.0001	175.0011	"	SR STREET	50	2005>	P	175.0001	175.0011
"	LEONARDO (MB00/H287)	125	1996	P	175.0001	175.0011	BETA	ARK (BS/K529) (BS4/e1/00114)	50	1997>	A	175.0001	175.0011
"	LEONARDO (MB00/H287)	125	1997-1998	P	175.0001	175.0011	"	ARK LC (BS/K529)	50	1999>	A	175.0001	175.0011
"	LEONARDO (MB00/H287)	125	1999>	P	175.0001	175.0011	"	ARK LC (BS/K529)	50	1999>	P	175.0001	175.0011
"	LEONARDO ST (MB/H689)	150	1999>	P	175.0001	175.0011	"	CHRONO 13	50	1994-1999	A	175.0001	175.0011
"	RALLY	50	1995-2000	A	175.0001	175.0011	"	TEMPO 13	50	1995-1996	A	175.0001	175.0011
"	RALLY LC (MD/H062)	50	1997>	A	175.0001	175.0011	GILERA	DNA 2T LC	50	2000>	P	175.0006 *	175.0016
"	RALLY LC (MD/H062)	50	1997>	P	175.0001	175.0011	"	EASY MOVING	50	1996>	A	175.0004	175.0014
"	SCARABEO DE-LUX	50	1998>	P	175.0001	175.0011	"	NRG	50	1994>	A	175.0001	175.0011
"	SCARABEO DITECH (SC,TG,TH/EBE)	50	2001>	P	175.0001	175.0011	"	STALKER DD (C13/H675)	50	1997-2001	A	175.0001	175.0011
"	SONIC (PB/K002)	50	1998>	A	175.0004	175.0014	"	STALKER DT	50	1997-2005	A	175.0001	175.0011
"	SONIC GP (PB/K002)	50	1998>	A	175.0004	175.0014	"	STORM	50	1994>	A	175.0001	175.0011
"	SR	50	1994-2000	A	175.0001	175.0011	"	TYPHOON	50	1993>	A	175.0001	175.0011
"	SR (PX/K508)	150	1999-2003	A	175.0001	175.0011	"	TYPHOON X	50	1993>	A	175.0001	175.0011
"	SR (PX125/K4740)	125	1999-2003	A	175.0001	175.0011	HONDA	BALI SJ (AF32/H030)	50	1993-1997	A	175.0005	175.0015
"	SR 2004 CARBURATORE (PIAGGIO)	50		A	175.0001	175.0011	"	BALI SJ (HF07/H328)	100	1996>	A	175.0005	175.0015
"	SR DITECH (RL/e3/0012)	50	2001-2006	A	175.0001	175.0011	"	CH SPACY	125	1998>	A	175.0005	175.0015

MARCA BRAND	MODELLO MODEL	CC	ANNO YEAR	A=Ant. Front P=Post. Rear	FLOATING DISC	FIXED DISC
"	SKY DX (AF43/H893)	50	1997>	A	175.0005	175.0015
"	YUPI	50	1990>	A	175.0005	175.0015
MALAGUTI	F 12 - PHANTOM	50	1994-1997	A	175.0001	175.0011
"	F 12 - PHANTOM	50	1998>	A	175.0001	175.0011
"	F 12 - PHANTOM LC	50	1995-1997	A	175.0001	175.0011
"	F 12 - PHANTOM LC	50	1998>	A	175.0001	175.0011
"	F 12 DIGIT KAT- PHANTOM	50	2000>	A	175.0001	175.0011
"	F 12 DIGIT KAT- PHANTOM LC	50	2000>	A	175.0001	175.0011
"	F 12 R ARIA	50		A	175.0001	175.0011
"	F 12 R LC	50		A	175.0001	175.0011
"	F10	50	1992-1994	A	175.0003	175.0013
"	F10	50	1995-2005	A	175.0003	175.0013
"	F10 JET LINE	50	1997-1999	A	175.0003	175.0013
"	YESTERDAY (45/H969)	50	1997-2001	A	175.0003	175.0013
MBK	BOOSTER 12"	50	2000-2006	A	175.0002	175.0012
"	BOOSTER NG (4VA/H268)	50	1997>	A	175.0005	175.0015
"	BOOSTER R - NG - ROCKET Euro 0-1	50	1993-1995	A	175.0004	175.0014
"	BOOSTER SPIRIT Euro 2	50	1999-2005	A	175.0002	175.0012
"	BOOSTER SPIRIT Euro 0-1	50	1996-1998	A	175.0004	175.0014
"	EVOLIS	50	1992-1994	A	175.0004	175.0014
"	EVOLIS	80	1994>	A	175.0004	175.0014
"	FIZZ	50	1994>	A	175.0004	175.0014
"	FORTE	50	1994>	A	175.0004	175.0014
"	NITRO (5BR/H949)	50	1997-2000	A	175.0005	175.0015
"	NITRO (5BR/H949)	50	1997-2000	P	175.0005	175.0015
"	NITRO (SA14/e13/0036)	50	2001>	A	175.0005	175.0015
"	NITRO (SA14/e13/0036)	50	2001>	P	175.0005	175.0015
"	NITRO (SB05/e13/0016)	100	1999>	A	175.0005	175.0015
"	OVETTO (5AD/H744)	50	1997>	A	175.0001	175.0011
"	OVETTO YN (SB04/e9/0016)	100	2000>	A	175.0001	175.0011
"	STUNT (SA09/e13/0017)	50	2000>	A	175.0005	175.0015
"	TARGET	50	1992-1994	A	175.0004	175.0014
MOTRON	COMPACT WF	50	1988-1992	A	175.0003	175.0013
PEUGEOT	ZENITH LUXE	50	1996>	A	175.0003	175.0013
PGO	BIG MAX	50	1994-2002	A	175.0004	175.0014
"	BIG MAX	80	1995>	A	175.0004	175.0014
"	MEGA FIFTY	50	1999	A	175.0004	175.0014
"	PMS	50	1999	A	175.0005	175.0015
"	PMS	110	1999>	A	175.0005	175.0015
"	PMX (PM50/)	50	1997>	A	175.0004	175.0014
"	T REX	110	1999>	A	175.0005	175.0015
"	T REX (CP/e12/0007)	50	1999>	A	175.0005	175.0015
PIAGGIO	FLY (LEADER) Euro 2-3	125		A	175.0006 *	175.0016
"	FLY (LEADER) Euro 2-3	150		A	175.0006 *	175.0016
"	HEXAGON 2T LC LX	125	1998>	A	175.0006 *	175.0016
"	HEXAGON 2T LC LXT	180	1998>	A	175.0006 *	175.0016
"	HEXAGON 4T LX4	125		A	175.0006 *	175.0016
"	NRG (SAL/H123)	50	1993-1995	A	175.0001	175.0011

MARCA BRAND	MODELLO MODEL	CC	ANNO YEAR	A=Ant. Front P=Post. Rear	FLOATING DISC	FIXED DISC
"	NRG (SAL/H123/0)	50	1996-2001	A	175.0001	175.0011
"	NTT	50	1994	A	175.0001	175.0011
"	NTT	50	1996>	A	175.0001	175.0011
"	SFERA 2T RESTYLING	50		A	175.0006 *	175.0016
"	VESPA ET2 2T	50	1997>	A	175.0006 *	175.0016
"	VESPA ET2 2T CARBURATORE	50	1997>	A	175.0006 *	175.0016
"	VESPA ET4 (LEADER) 4T	125	1999>	A	175.0006 *	175.0016
"	VESPA ET4 (LEADER) 4T	150	1999>	A	175.0006 *	175.0016
"	VESPA ET4 4T	125	1996>	A	175.0006 *	175.0016
"	VESPA LX (LEADER) 4T	125		A	175.0006 *	175.0016
"	VESPA LX (LEADER) 4T	150		A	175.0006 *	175.0016
"	VESPA PX Euro 2	125	1998>2001	A	175.0006 *	175.0016
"	VESPA PX Euro 2	150	1998>2001	A	175.0006 *	175.0016
"	VESPA PX Euro 2	200	1998>2001	A	175.0006 *	175.0016
"	VESPA S 2T Euro 2	50		A	175.0006 *	175.0016
"	VESPA S 4V Euro 2 4T	50		A	175.0006 *	175.0016
"	VESPA S Euro 3 4T	125		A	175.0006 *	175.0016
"	VESPA S Euro 3 4T	150		A	175.0006 *	175.0016
"	ZIP 4T	125	2000>	A	175.0006 *	175.0016
"	ZIP FAST RIDER 2T (SSL/G357)	50	1993-1995	A	175.0004	175.0014
"	ZIP FAST RIDER 2T (SSL/G357)	50	1996-2000	A	175.0004	175.0014
"	ZIP SP H20	50	2001>	A	175.0006 *	175.0016
VILLA	AX	50	1993>	A	175.0004	175.0014
"	GZ	50	1993>	A	175.0004	175.0014
YAMAHA	AEROX (SB05/e13/0016)	100	2000-2002	A	175.0005	175.0015
"	AEROX (SB05/e13/0016)	100	2000-2002	P	175.0005	175.0015
"	AEROX YQ (5BR/EBE) (SA14/e13/0036)	50	1997>	A	175.0005	175.0015
"	AEROX YQ (5BR/EBE) (SA14/e13/0036)	50	1997>	P	175.0005	175.0015
"	AXIS	50	1994>	A	175.0004	175.0014
"	BREEZE YM (4RC/G929)	50	1994>	A	175.0004	175.0014
"	BUMP (4VA/H268)	50	1997-2001	A	175.0002	175.0012
"	BW'S	50	1993-1995	A	175.0004	175.0014
"	BW'S	50	1996-1998	A	175.0004	175.0014
"	BW'S	50	1999-2003	A	175.0002	175.0012
"	BW'S	50	2000-2006	A	175.0002	175.0012
"	BW'S NG (4BXM/G370) Euro 2	50	1996>	A	175.0002	175.0012
"	CR Z (4FW/-)	50	1992-1995	A	175.0004	175.0014
"	JOG R/ RR (SA22/e9/0079)	50	2002>	A	175.0005	175.0015
"	JOG Z	50	1991>	A	175.0004	175.0014
"	NEO'S (SB04/e9/0016)	100	2000>	A	175.0001	175.0011
"	NEO'S YN (5AD/H744)	50	1997>	A	175.0001	175.0011
"	SLIDER (SA09/e13/0017)	50	1999>	A	175.0001	175.0011
"	SPY	50	1995>	A	175.0002	175.0012
"	T-MAX	500	2008>	A	175.0008	

* Solo per uso agonistico in pista montare il cod.175.0007 (disco senza molle antirumore) - Fit item 175.0007 (disc without noise-abating spring) only for race use on track.

SPECIAL